

*Unparalleled, Choice CNC Grinding Solutions*

**RDC-20CNC  
Double - Feed Centerless  
Grinding Machine**

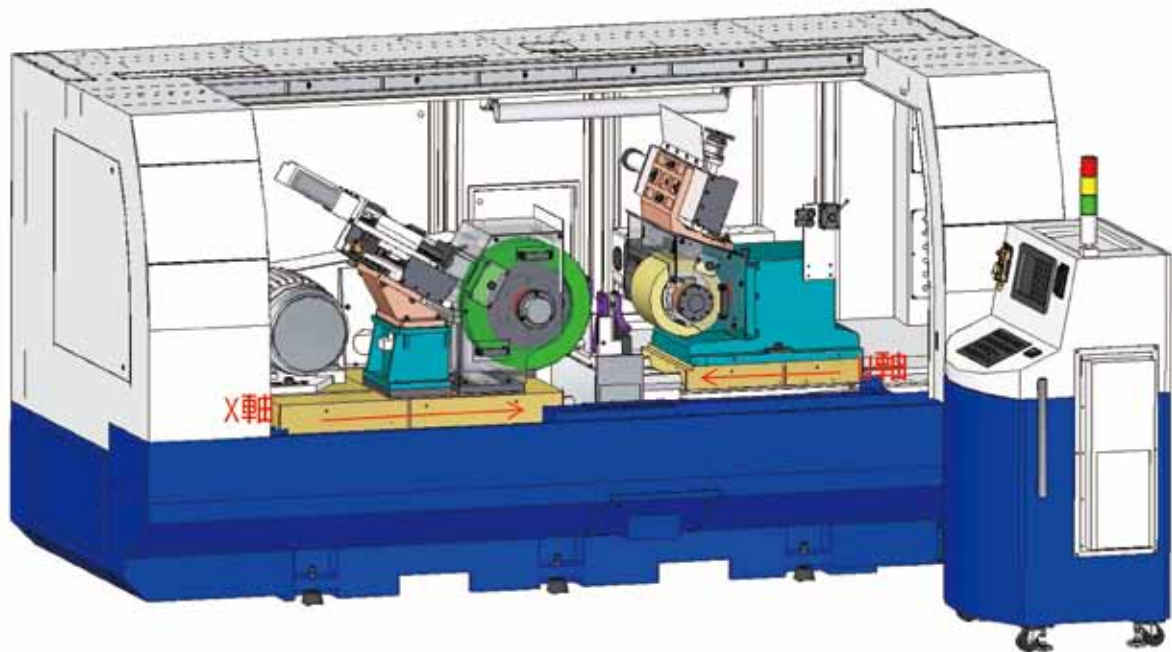

**Features :**

- Through finite element computer-aided analysis of stress and deformation, machine base structure can ensure overall optimal rigidity and precision.
- Great span of guideways and wide surface, accurate hand-scraping with class C1 ballscrew.
- Through double feed from both grinding wheel slide & regulating wheel slide, and rapid adjustment of work rest height, long bar grinding and large components are applicable, to save tuning time.
- Grinding diameter ranges from  $\varnothing 3$  to  $\varnothing 250$ , suitable for wide fields of industries.

# RDC-20CNC Specication

Item		Unit	RDC-20CNC
Capacity	Grinding range (dia.)	mm	3~ 250
Control system	Controller	set	FANUC / SIEMENS / MITSUBISHI
Grinding wheel	Dimensions	mm	Ø510x205(255op)xØ304.8
	Grinding wheel speed	m/min	2000
Regulating wheel	Dimensions	mm	Ø305x205xØ177.8
	Regulating wheel speed	rpm	10-300
	Swivel angle	deg	±5°
	Tilt angle	deg	±5°
Driven motor	Grinding wheel motor	HP	40
	Hydraulic pump	HP	1
	Coolant pump motor	HP	1/4
	Regulating wheel servo motor	kw	2.9
	Grinding wheel feed motor	kw	4
	Regulating wheel feed motor	kw	4
	Grinding wheel dressing traverse motor	kw	0.75
	Grinding wheel dressing feed motor	kw	0.75
Others	Machine dimensions(L. * W. * H.)	mm	5,740x4,245x2,000
	Machine weight	kg	5,100

Design and specification are subject to change without prior notice.

## Standard Accessories

- CNC Controller
- Coolant Tank with Pump
- Work Lamp
- Tools + Kits
- Wheel Flange Extractor
- Automatic Lubricator
- Electric Cabinet Heat Exchanger
- Servo Motor for Regulating Wheel
- Grinding Wheel, Grinding Wheel Flange
- Diamond Dresser
- Hydraulic Tank with Pump

- Hydraulic Oil Cooler
- Infeed Work Rest + Carbide Blade
- Thrufeed Work Rest + Carbide Blade
- Workpiece Pressor

## Optional Accessories

- Inverter
- Linear Scale
- Paper Filter
- Magnetic Coolant Separator
- Hydrocyclone Coolant Separator
- Automatic Loading Attachment for Infeed Grinding

- Automatic Unloading Attachment for Infeed Grinding
- Work Ejector (Hydraulic / Air)
- Supporter for Long Bar Grinding
- Vibration Meter
- Grinding Wheel Face Dressing Unit
- Rotary-type Dressing Unit
- Profile template (Regulating Wheel)
- Special Thrufeed Work Rest (Small Diameter)

Machine Layout

Unit:mm

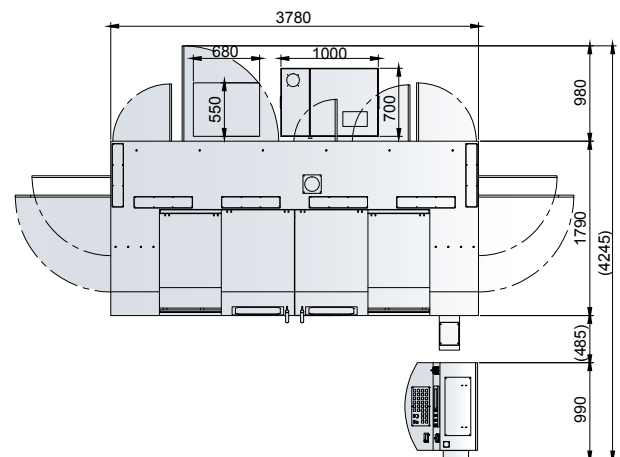

## 榮光機械股份有限公司

台灣 42757 台中市潭子區潭興路二段 63 巷 2 號

**PARAGON MACHINERY CO., LTD.**

No. 2, Lane 63, Sec. 2, Tanxing Rd. Tanzi, Taichung  
42757, Taiwan

TEL : +886-4-2539-5678

FAX : +886-4-2539-3399

e-mail : [info@paragoncnc.com](mailto:info@paragoncnc.com)

<http://www.paragoncnc.com>